



FALL SHIELD™

HIGH LIFT
DUAL TRACK

COMPANY		PREPARED BY	
EMAIL		PHONE NUMBER	
ADDRESS			
CITY		STATE	ZIP
PURCHASE ORDER NUMBER		DATE REQUIRED	QTY
TAG			
SPECIAL INSTRUCTIONS (Please note if this is for a quote)			

- A** Is there any interference for new track? Yes No
- B** Floor to Existing Horizontal Track: _____ ft _____ in
- C** Opening Width: _____ ft _____ in
- D** Opening Height: _____ ft _____ in
- E** Distance From Existing Track to Bollard: _____ in
- F** Outside to Outside of Existing Track: _____ ft _____ in
- G** Existing Door Width: _____ ft _____ in
- H** Existing Door Height: _____ ft _____ in
- I** Existing lower track is in good condition: Yes No
- J** Existing Track Width: 2 in 3 in
- K** Rasco door to be motorized: Yes No
- L** Required Fall Shield Height: _____ ft
(Minimum 4 ft)
- M** Panel Finish, Select One:
 - Powder Coat Yellow
 - Mill Finish
 - Custom Color _____
- N** Rasco Door Track Size: 2 in 3 in
(2" is recommended as it has a 32" radius to accommodate the unusually tall sections.)

EMAIL SURVEY FORM TO RASCO

DOOR SIDE VIEW

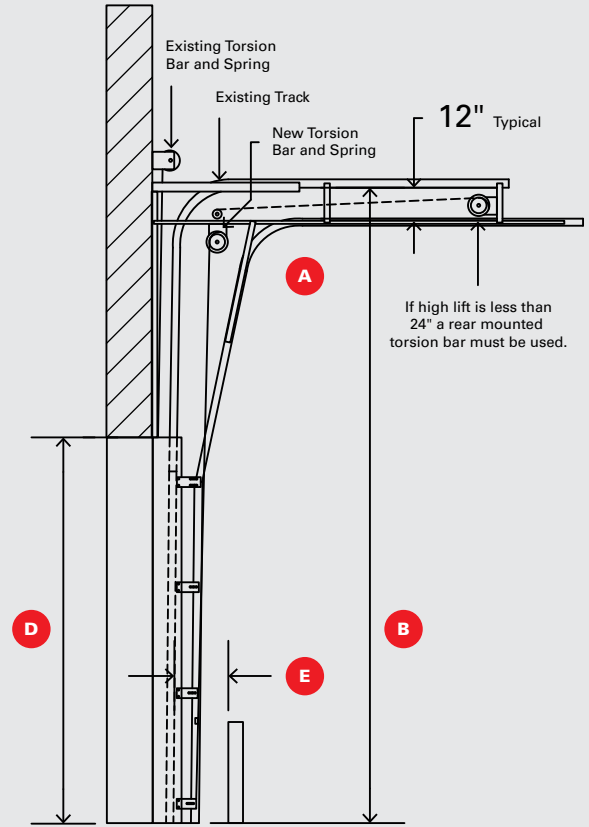

NOTES: A torsion bar support is required on all doors 10' or wider.
Dual track cannot be used if existing door has outside pull cables.

DOORTOP ABOVE

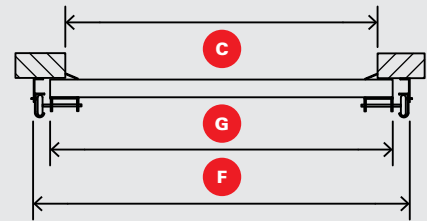

TRACK TOP DETAIL

